

TECHNICAL SUMMARY

IO/18/CFT/15622/JPA

Procurement of TCWS 1st Plasma Primary Support

Table of Contents

1	PURPOSE.....	3
2	SCOPE OF WORK.....	3
3	MATERIALS	5
4	ESTIMATED DURATION.....	5
5	EXPERIENCE	6
6	CANDIDATURE.....	6
7	LIST OF DELIVERABLES.....	6
8	REFERENCES.....	7

1 Purpose

The purpose of this Call for Nominations is to establish a Contract for the procurement of primary supports, required for the ITER project / Tokamak Cooling Water System (TCWS).

These primary supports include Component Standard Supports (CSS) and Special Components (SC) that shall be delivered at ITER IO site.

2 Scope of work

The Contractor will be required to supply primary supports to the ITER Organization under the conditions of the Contract to be signed with the ITER Organization.

Table 1 represents the preliminary bill of materials of component standard supports (CSS) required for the TCWS. Please note that they are subject to change. This is an indicative list of deliverables.

Table 2 represents the preliminary bill of materials of special components (SC) required for the TCWS. Please note that they are subject to change. This is an indicative list of deliverables.

The scope of supply includes manufacturing, testing, qualification, cleaning, packaging and delivery of primary supports to the ITER site, France.

Table 1 – preliminary bill of materials - Component Standard Supports (subject to change)

item	quantity	DN or dimensions
Clamp	56	DN50 to DN450
Vertical pipe clamp	14	DN150 to DN450
clamp base	12	DN250 and DN 450
Two bolt pipe clamp	14	DN200
Three bolt pipe clip	14	DN150 and DN250
SS inlay plate for clamp	78	DN 65 to DN450
SS pipe strap	334	DN25 to DN150
U bolt	127	DN65 and DN150
Pipe whip restraints	1400	DN65 to DN450
Clevis with pin	62	various
Connection plate	3	various
constant hanger	23	various
Constant support	3	various
Eye nut	91	various
Hexagonal nut	88	various
Rigid Strut	407	various
shock absorbers	122	various

Extension for shock absorbers	79	various
Stud bolt	65	various
Tie Rod	6	various
Trapeze	13	various
Turnbuckle	3	various
Variable spring hanger	48	various
Weld-on Bracket	531	various
Weld-on clevis	55	various
Weld-on eye plate	14	various

Table 2 – preliminary bill of materials – Special Components (subject to change)

item	quantity	dimensions
single direction pipe shoe	547	DN20 to DN450
double guide pipe shoe	184	DN40 to DN450
special design pipe shoe	69	DN65 to DN350

Fig1. Single direction pipe shoe

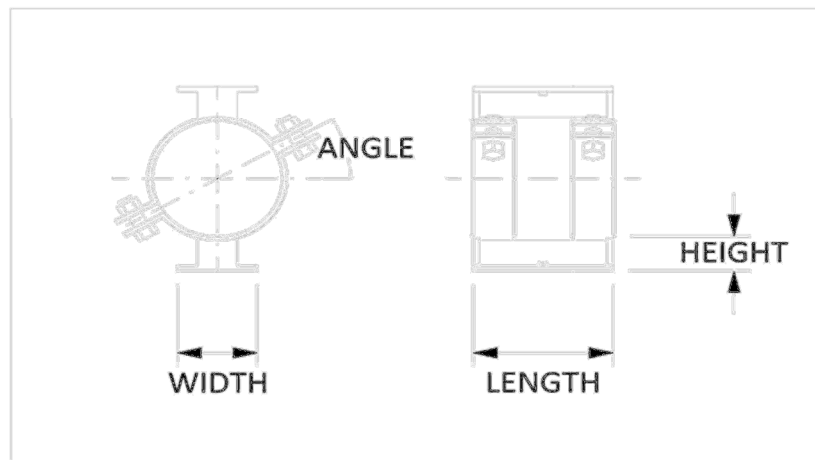

Fig2. Double guide pipe shoe

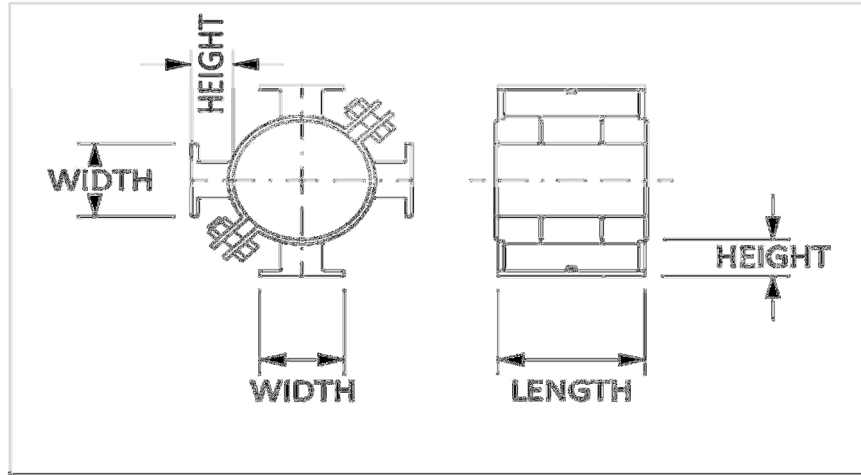
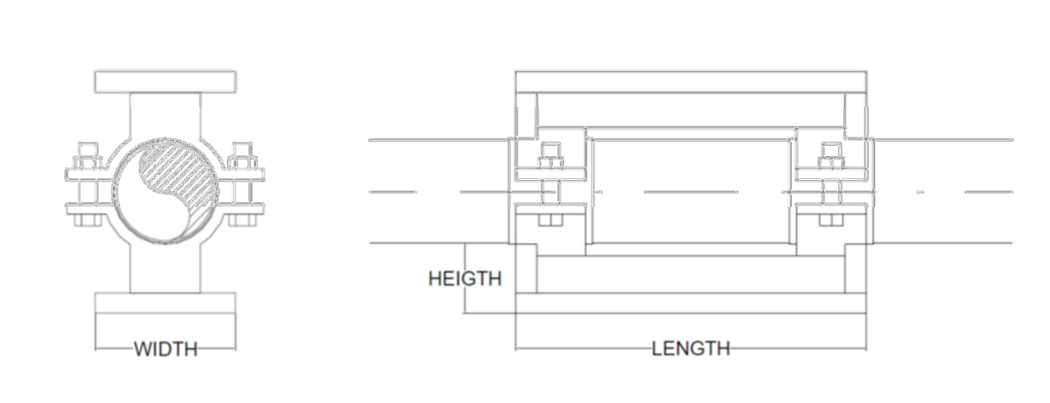

Fig3. Special design pipe shoe



3 Materials

All TCWS pipes are in stainless steel 304L. Supports in Cryostat shall be steel grade 304L with a low Cobalt content ($Co \leq 0.05\%$).

Supports out Cryostat should be in carbon steel but the parts in contact with stainless steel pipe as bases or straps shall be in stainless steel.

4 Estimated Duration

The duration of the contract will be approximately 3 years from the date of the award of the contract.

The tentative timetable is as follows:

- Call for Nominations April 2018
- Pre-Qualification Q3 2018 (combine Pre-Qual. w/ Call for Tender)

- Call for Tender Q3 2018 (2 offers needed – one technical one financial, catalogue price with a discount for ITER)
- Award of the Framework Contract Q4 2018
- Delivery Q1 2020- Q4 2021

The delivery of the material on IO site has to be completed by the 31st December 2021.

5 Experience

The Supplier shall have demonstrable experience in the manufacturing and supply of supports and components used in the nuclear industry, with customized dimensions, loads and travels. Supports and components are required to perform safety functions.

The Supplier shall be able to set-up a Quality Assurance System and Supply Chain Management System required for manufacturing of nuclear components.

6 Candidature

Participation is open to all legal persons participating either individually or in a grouping (consortium) which is established in an ITER Member State. A legal person cannot participate individually or as a consortium partner in more than one application or tender of the same contract. A consortium may be a permanent, legally-established grouping or a grouping, which has been constituted informally for a specific tender procedure. All members of a consortium (i.e. the leader and all other members) are jointly and severally liable to the ITER Organization.

The consortium grouping shall be presented at the Pre-Qualification stage. The Candidate's composition cannot be modified without the approval of the ITER Organization after the Pre-Qualification.

Legal entities belonging to the same legal group are allowed to participate separately if they are able to demonstrate independent technical and financial capacities. Candidates (individual or consortium) must comply with the selection criteria. The IO reserves the right to disregard duplicated reference projects and may exclude such legal entities from the Pre-Qualification procedure.

7 List of deliverables

The list of deliverables is provided in Table 3.

Table 3 – List of Deliverables

No	Deliverable	Description
1	Contractor List of Items	In this document the contractor will list the items to be delivered including type of items, the material, the dimensions, the quantities, weight per item.

2	Delivery plan	For each item the contractor will specify the delivery date on IO site, the transportation mean, and lifting gear. It shall also specify the list and number of packages prior to delivery. This document can be merged with the Contractor List of Items as one document.
3	Material certificate 3.1	As per standard EN 10204 for all the list of items presented in this technical specification.
4	Certificate of Conformity	CE certificate of conformity shall be provided where applicable
5	Snubbers - Test certificate	For shock absorbers, a test certificate shall be provided for function parameters.
6	Packing List	In this document the contractor will specify the content of each shipment to IO site separated into IO reference building including number of packages, content of each package, dimensions of each package, weight of each package
7	Declaration of Conformity	The contractor shall include with the packing list, a declaration of conformity specifying that items that have been sent conform with the order signed by IO
8	Items to be delivered to the IO site	The list of items mentioned in the contract.

8 References

- [1].ASME B31.3 code for pressure piping, 2014 edition
- [2].ASME III div.1 rule for construction of nuclear facility components, 2017 edition
- [3].Directive 2014/68/EU – Pressure Equipment of the European Parliament and of the Council of 15 May 2014
- [4].ESPN - Equipement Sous Pression Nucleaire - French Order 2015 December 30th for nuclear pressurised equipment (ESPN)
- [5].NF EN 13480-4 – Metallic industrial Piping – Part 4 : Fabrication and installation -15 december 2017
- [6].NF EN 10204- Metallic products – Types of inspection documents - January 2005