



idm@F4E UID / VERSION

2693FC / 1.6

VERSION CREATED ON / STATUS

10 November 2017 / Approved

EXTERNAL REFERENCE

Quality Document F4E-QA-117 Dimensional Metrology Handbook (DMH)

The purpose of this document is to supply information relating to dimensional metrology to all Fusion For Energy suppliers and project teams.

<i>Approval Process</i>			
	<i>Name</i>	<i>Action</i>	<i>Affiliation</i>
<i>Author</i>	Calchi G.	10 November 2017:signed	ITERD
<i>Co-Authors</i>			
<i>Reviewers</i>	Ilves J. Rodrigues D. Semeraro L.	10 November 2017:recommended 13 November 2017:recommended (Fast Track) 10 November 2017:recommended	PM ADM ITERD
<i>Approver</i>	Chaffard P.- Y.	13 November 2017:approved	ITERD
<i>RO: Rodrigues Diogo (F4E)</i>			
<i>Read Access</i>	LG: F4E_QAO, AD: IDM_Users, GG: IAS Audit on Document Management, project administrator, RO, LG: OPE647-CRPP-Annex B applicable and ref docs, AD: IDM_F4E, AD: IDM CL-CP-PP-00 Project Procurement, AD: IDM IE-PE-00-00 Antennas and Plasma Engineering, GG: IAC, LG: EC Extended Design Team, LG: EC_ITER T...		

Original Document MD5#: 79F66EE6D8155F8975E4CBBE14A8E4C1

Change Log

F4E-QA-117 Dimensional Metrology Handbook (DMH) (2693FC)

<i>Version</i>	<i>Latest Status</i>	<i>Issue Date</i>	<i>Description of Change</i>
v0.0	In Work	11 February 2013	
v1.0	Signed	15 February 2013	First Issue
v1.1	Signed	26 February 2013	Inserted comments of PYC and GS
v1.2	Approved	25 March 2013	replaced the term Dimension Control Plan with Metrology Inspection Plan
v1.3	Approved	26 October 2015	New terms added: -FAT Factory Acceptance Test -SAT Site Acceptance Test Section: II.1 A&M Class 1 completed with FAT/SAT phases. New sections added: III.6 Mandatory Requirements for Procurement and III.7 Mandatory Requirements Summary
v1.4	In Work	27 October 2017	<ul style="list-style-type: none"> - Reference to ISO 14253-1 added and included in [MRS8], [MRP8] - Reference to ISO GUM added - References to new F4E Metrology documents added: QA-117 inspection procedure, Dimensional Inspection Plan template, Allowable temperature gradients, Load compensation - Abbreviations updated - Definition of A&M Classes 1 and 2 updated to take into account assemblies' importance - Instruments' calibration requirements updated in [MRS7] and [MRP6], subsection VIII.3 (b) added, detailing new calibration requirements - [MRP9] modified to include time intervals for temperature measurement, temperature gradients and variation with time - Reports requirements in [MRP13] modified - [MRP10], [MRP13] now applicable to all Alignment & Metrology Classes, report requirements are now differentiated by Classes - Drift check added in section VIII.1 - Subsection VIII.7(d) added, considering temperature gradients - Section VIII.11 added to give guidance on the unique measurement identification, [MRP7] updated accordingly - Typos corrected Modified where indicated
v1.5	Signed	27 October 2017	<ul style="list-style-type: none"> - Native file uploaded in IDM Modified where indicated, with respect to v1.3 for better traceability
v1.6	Approved	10 November 2017	<ul style="list-style-type: none"> - Reference document [8] (QA-117 inspection procedure) removed Modified where indicated, with respect to v1.3 for better traceability



HANDBOOK

Control Page

idm@F4E ref:	F4E_D_2693FC	Date:	10.Nov.2017
--------------	--------------	-------	-------------

Document title:	F4E Dimensional Metrology Handbook (DMH)
-----------------	--

Areas and functions

Policy ownership:	ITER Department HoD
Area(s) concerned:	Operational expenditure
Function(s) concerned:	Technical Project Officer and Quality Officer

Purpose

The purpose of this document is to supply information relating to dimensional metrology to all Fusion for Energy suppliers and Project teams. To define strategies and infrastructure provision, identify requirements and best practises and provide a standardised approach to dimensional control and alignment processes.

Scope

(a) The Dimensional Metrology Handbook (DMH) outlines the mandatory requirements for dimensional control of the components, assemblies and systems for the ITER machine. In addition the handbook provides significant guidance and helpful information on best practice for large volume metrology applications. The handbook also provides information on the ITER metrology infrastructure and the provision of alignment and metrology services during assembly of the machine and its ancillary components and systems.

(b) The DMH is issued as a supplement to project requirements documents, since it is necessary that the requirements contained in this handbook are followed by F4E, and industry to ensure the successful construction and operation of the ITER machine.

Table of contents

I. Communications and acceptance	4
II. Alignment and Metrology (A&M) Classifications.....	4
II.1. A&M Class 1.....	4
II.2. A&M Class 2.....	4
II.3. A&M Class 3.....	4
II.4. Unclassified	4
III. Mandatory Requirements for A&M Tasks.....	6
III.1. Mandatory Requirements for Site (MRS) based A&M Class 1 Activities	6
III.2. Mandatory Requirements for Site (MRS) Based A&M Class 2 Activities	8
III.3. Mandatory Requirements for Site (MRS) Based A&M Class 3 Activities	8
III.4. Mandatory Requirements Procurement (MRP) for A&M Class 1 Activities.....	8
III.5. Mandatory Requirements Procurement (MRP) for A&M Class 2 Activities.....	11
III.6. Mandatory Requirements for Procurement (MRP) A&M Class 3 Activities.....	11
III.7. Summary of Mandatory Requirements for Procurement.....	11
IV. Standards.....	13
V. Infrastructure - Survey Networks and Datum	14

V.1. Primary Survey Network.....	14
V.2. Tokamak Pit Network	15
V.3. Tokamak Galleries Networks	15
V.4. Generic Buildings Networks	15
V.5. Assembly Datum	16
VI. Survey and Alignment During Buildings Construction.....	17
VII. Design for Alignment and Metrology	18
VIII. Process Control and Best Practice	19
VIII.1. Large Volume Portable Measurement Systems	19
VIII.2. Best-fit Analysis and Alignment Transformations.....	20
VIII.3. Control of Inspection Measurement and Test Equipment	20
VIII.4. Coordinate Systems and Measurement Units	21
VIII.5. Metrology Software and Data Formats.....	21
VIII.6. Measurement Uncertainty	22
VIII.7. Measurement Scale	22
VIII.8. Component Orientation and Fixturing for Measurement	23
VIII.9. Fiducialisation.....	23
VIII.10. Targets and Tooling	23
VIII.11. Identification of metrology requirements	24
IX. Coordination for Metrology Activities.....	24
IX.1. Interface Control	25
IX.2. Design Reviews.....	25
X. Quality and Documentation.....	26

Reference documents

- [1] [Supplier Quality Requirements \(F4E-QA-115, F4E_D_22F8BJ\)](#)
- [2] [F4E QA Programme for the ITER project \(F4E-QA-P-IO, F4E_D_22MCBA\)](#)
- [3] [System Requirements Document SRD 62-13 Lay-down and Assembly Hall \(ITER_D_2F7RGN\)](#)
- [4] [ITER Coordinate Systems \(ITER_D_2A9PXZ\)](#)
- [5] [F4E Design Review Procedure \(F4E_D_23NYBM\)](#)
- [6] BS EN ISO/IEC 17025 : 2005 - General requirements for the competence of testing and calibration laboratories
- [7] ISO 14253-1:2013 - Geometrical product specifications (GPS) -- Inspection by measurement of workpieces and measuring equipment -- Part 1: Decision rules for proving conformity or nonconformity with specifications
- [8] [Dimensional Inspection Plan template \(F4E_D_24UJ8L\)](#)
- [9] [ISO Guide for the Expression of Uncertainty in Measurements \(JCGM 100:2008\)](#)
- [10] [Allowable temperature gradients \(F4E_D_27RSEN\)](#)
- [11] [Load compensation \(F4E_D_27AZ4Z\)](#)

Abbreviations

3D	Three Dimensional
A&M	Alignment and Metrology
AIMS	Advanced Integrated Mathematical System
ASCII	American Standard Code for Information Exchange
CAD	Computer Aided Design

CBD	Cryostat Base Datum
CCL	Current Centreline
CCR	Corner Cube Reflector
CMM	Coordinate Measuring Machine
CMx	Compliance matrix document
DA	Domestic Agency
DCM	Design Compliance Matrix
DMH	Dimensional Metrology Handbook
DMIS	Dimensional Measurement Interface Standard
FAT	Factory Acceptance Test
F4E	Fusion For Energy
GD&T	Geometric Dimensioning and Tolerance
GPS	Geometrical Product Specifications
ICD	Interface Control Document
IDM	ITER (and F4E) Document Management System
IGES	Initial Graphics Exchange Specification
IO	ITER Organization
IS	Interface Sheet
LVM	Large Volume Metrology
DIP	Dimensional Inspection Plan
MRP	Mandatory Requirements for Procurement
MRS	Mandatory Requirement for Site
NRK	New River Kinematics
PA	Procurement Arrangement
PF	Raw 3D Scan data Format
PIF	Parametric Image Format
PIT	Pit Datum
POL	InnovMetric's Binary Format
RO	Responsible Officer
SA	Spatial Analyzer
SAT	Site Acceptance Test
SMR	Spherically Mounted Reflector
SRD	System Requirements Document
STEP	Standardised Exchange of Product
TAD	Tokamak Assembly Datum
TPO	Technical Project Officer
TF	Toroidal Field
TFGS	Toroidal Field coil Gravity Support
TGCS	Tokamak Global Coordinate System
VCD	Verification Control Document
VVGS	Vacuum Vessel Gravity Support

I. Communications and acceptance

(a) To satisfy the requirements of this handbook, processes and procedures relating to alignment and dimensional control must be clearly documented and where stated: approved or accepted by the Metrology officer or nominated representative.

(b) Section VIII and its sub-sections "[Process control and best practise](#)" identify areas that will be reviewed prior, during and on completion of the activity and will require F4E acceptance at predefined stages. *Acceptance/Approval* is to be a positive and recorded action, either by signature or by electronic means.

(c) A possible route of communication and acceptance could be:

Supplier (Contractor) ↔ F4E Contract Technical Officer ↔ F4E Metrology Officer ↔ ITER Site representative.

II. Alignment and Metrology (A&M) Classifications

(a) Machine components and plant systems requiring alignment and/or dimensional control must be given an A&M classification by the applicable technical officer. The typical approval process will follow the communication and acceptance path as described in the previous section.

(b) The classification must reflect the importance placed on A&M for the system to function and the consequence of failure on the project. This classification must be reviewed and accepted by the F4E Metrology Officer.

II.1. A&M Class 1

(a) Measurements requiring alignment and/or dimensional control, where failure to comply in these areas will significantly impair or prevent machine assembly and/or operation and could potentially cause schedule delay in excess of one month or cost risk in excess of 1 M€

(b) Measurements requiring alignment and/or dimensional control during FAT or SAT phases

(c) Measurements of features having an impact on health and safety or component structural stability

(d) Measurements defining the interfaces between adjacent assemblies or work packages, where failure to assemble them could potentially cause schedule delay in excess of one month or cost risk in excess of 1 M€

II.2. A&M Class 2

(a) Measurements requiring alignment and/or dimensional control, where failure to comply in these areas will significantly impair or prevent machine assembly and/or operation and could potentially cause schedule delay in excess of one week or cost risk in excess of 0.1 M€

(b) Measurements defining the interfaces between adjacent assemblies, where failure to assemble them could potentially cause schedule delay in excess of one week or cost risk in excess of 0.1 M€

II.3. A&M Class 3

Measurements requiring alignment and/or dimensional control, where failure to comply in these areas will not impair or prevent machine assembly and/or operation and could potentially cause schedule delay in less of one week or cost risk in less of 0.1 M€.

II.4. Unclassified

No infrastructure required or support from F4E or ITER metrology teams.

No dimensional control oversight by F4E is required through the supply chain or on receipt at the ITER site. No component alignment requirements however setting out points/lines will be required

from the ITER site metrology team to facilitate the installation. Unclassified measurements will be taken according company quality manual and standards.

Note:

It is the responsibility of the Technical project Officer to make an assessment of the A&M requirements for the system following the processes in this document in order to determine the A&M class, which must be reviewed by the metrology officer.

III. Mandatory Requirements for A&M Tasks

(a) For the ITER machine to operate to specification it is essential that the supply of its constituent parts is controlled throughout their life cycle from raw material through manufacture, assembly commissioning and operation. From a metrology perspective this means that dimensional control processes must be qualified and traceable.

(b) The Metrology Officer shall be available to provide technical advice to system technical officers during preparation of Technical Specifications, reviewing metrology related documentation and providing support where necessary during manufacture, assembly/installation and acceptance.

(c) In the following sections, information is provided on best practice guidance for metrology related processes and will be used as the basis for reviewing process documentation relating to dimensional control activities.

(d) Within this section are the mandatory requirements relating to A&M for the supply and assembly/installation of the systems for the ITER project. If an exception to a mandatory requirement is requested it must be agreed by F4E through the deviation process.

(e) Mandatory requirements relating to A&M are dependent on the A&M classification applicable ([section II](#)) to the component or assembly concerned. These requirements are detailed in the following sub-sections.

III.1. Mandatory Requirements for Site (MRS) based A&M Class 1 Activities

(a) A&M Class 1 activities are critical to the successful assembly/installation and operation of the ITER machine and as such require the highest level of qualification and control.

(b) Listed below are the mandatory requirements, as applicable for the system concerned, identifying responsibilities for their delivery and acceptance. The Metrology Officer shall review all key documents pertaining to A&M tasks within this classification.

[MRS1] The System Requirements Document (SRD), Interface Control Document (ICD) or other document issued by ITER IO, define the alignment and/or dimensional control requirements. These must be included in the Design Compliance Matrix (DCM) and the methods to achieve them must be reviewed and approved as part of the Design Review Procedure with the Metrology Officer accepting the process for the A&M tasks.

[MRS2] The TPO must identify all A&M quality documentation that will form part of the supply for the applicable system. The dossier of documents must be certified compliant with the requirements of the technical specification or must be supported by a nonconformity report. This must be in place prior to any A&M work commencing at the ITER site.

[MRS3] For items requiring goods inwards, in-process or final inspection, a list of key characteristics must be compiled by the technical officer to identify the scope of the inspection. Datum and tolerances must be identified in a drawing or other medium acceptable to the inspection team carrying out the task. A method statement or procedure must be prepared by the party responsible for the inspection which must be accepted by the Metrology Officer.

[MRS4] For items requiring setting out, pre-alignment and/or final alignment at the ITER site, a procedure must be prepared detailing the requirements, process description, reference data, output data together with reporting and acceptance criteria. This procedure must be accepted by the Metrology Officer prior to task commencement.

[MRS5] The coordinate/datum systems used during inspection and alignment tasks on the ITER site must be clearly defined in the A&M procedure for the task and applicable drawings.

Where datum evolves to reflect as-built variation in the assembly/installation process the logic must be traceable back to the nominal requirement.

- [MRS6] Inspection reports must identify the nominal dimensions, applicable tolerances and the dimension achieved for the feature, with non-complying values flagged in red on the report. These features must be the subject of rework or a nonconformity report.
- [MRS7] All metrology equipment used for A&M tasks must be calibrated and controlled in accordance with subsection VIII.3. The equipment selected by the supplier must be fit for the requirements of the measurement process considering areas such as: measurement uncertainty, speed of data acquisition, measurement geometry, local environmental conditions etc.
- [MRS8] Measurement uncertainty must be calculated for all reported measurements at a confidence level of 2σ . As a general rule, the uncertainty value must not exceed 20% of the tolerance applicable to the feature measured. If the uncertainty value exceeds this threshold, rules defined in ISO 14253-1:2013 shall apply. See subsection VIII.6 for the rationale behind these rules. Maintaining an uncertainty of 10% or less is recommended to optimise the available tolerance applicable to the feature concerned.
- [MRS9] The Project drawings specify dimensions at the reference temperature of 20°C. The environmental conditions for A&M will depend very much on the location in which the activity is to be carried out. The TPO shall make an assessment of the impact of thermal expansion/contraction on the A&M task and specify controls to be put in place as necessary to compensate. Consideration must be given to the thermal inertia of the components being measured, where necessary allowing sufficient soak time in the measurement environment to ensure thermal stabilisation. For critical items temperature measurements (better than $\pm 1^\circ\text{C}$) must be recorded throughout the measurement task of both the component and the environment, logged against time and saved with the measurement file. For large components, multiple measurements must be required to enable the detection of thermal gradients.
- [MRS10] For measurement surveys utilising multiple instrument stations, bundle adjustment algorithms must be used to ensure error propagation, via multiple best-fit alignments, does not occur.
- [MRS11] All “as-built” drawings/3D models/electronic data must be supplied in Catia V5 format.
- [MRS12] All inspection/dimensional control and alignment reports must include, as a minimum, the following information:
- Identification of measuring instruments used including the calibration certificate reference
 - Identification of ancillary equipment, as applicable, used including type, make unique identifier and calibration certificate number i.e.
 - Test unit
 - Probes (dimensions, frequencies)
 - Targets and tooling
 - Scale bars
 - Identification of the part examined
 - Reference drawing or CAD model identification defining the tolerances, datum etc. which the part has been inspected to, including issue status

- Time and place of the inspection plus signature of the operator
- Name and qualification of the operator and the employer.
- Procedure followed and issue status
- Meteorological data (temperature, humidity, pressure)
- Identification of all computer files generated during the inspection, all raw and processed data must be in a format acceptable to F4E
- Written values tabulated to provide: nominal dimensions, applicable tolerances and the dimension achieved for the feature, with non-complying values flagged in red on the report. Graphical data may be used if agreed by F4E.
- Interpretation of results, including an explanation for any readings considered invalid.
- Identification of any nonconformity reports raised.

[MRS13] All drawings and/or electronic data used for A&M activities must be issued through the F4E document control process and certified at the status to which they must be used.

III.2. Mandatory Requirements for Site (MRS) Based A&M Class 2 Activities

(a) Components or assemblies with an A&M class 2 will require a significant amount of dimensional control at the ITER site. They may need to go through a pre-alignment process to provide references (fiducials) for assembly/installation and may also need inspections during and on completion of assembly/installation.

(b) A&M class 2 tasks however have a reduced impact on cost and schedule in the event of failure therefore requiring a reduced level of input by the Metrology Officer.

(c) The A&M class 1 mandatory requirements [MRS1] through to [MRS13] must be maintained for this classification, as applicable to the task, but the requirement for review/approval by the Metrology officer is removed.

III.3. Mandatory Requirements for Site (MRS) Based A&M Class 3 Activities

A&M class 3 activities only require setting out points/lines to facilitate their installation therefore the mandatory requirements for these activities are [MRS4], [MRS7] and [MRS13].

III.4. Mandatory Requirements Procurement (MRP) for A&M Class 1 Activities

A&M Class 1 activities are critical to the successful assembly/installation and operation of the ITER machine and as such require the highest level of qualification and control. Listed below are the mandatory requirements, as applicable for the system concerned, identifying responsibilities for their delivery and approval. The F4E Metrology Officer must be given the opportunity to review all key documents pertaining to A&M tasks within this classification.

[MRP1] F4E System Requirement Document, Interface Control Document (ICD) or other document, define the alignment and/or dimensional control requirements relating to the subject of the procurement. These must be included in the Compliance Matrix (CMx) and Verification Document (VCD) and must be reviewed as part of the Design Review Procedure.

[MRP2] The A&M requirements for the procurement must be included within the Technical Specification (Annex B) with design drawings and associated design documents defining the fundamental design dimensions and tolerances. The supplier shall produce shop floor documentation that demonstrates how the manufacturing and/or assembly process

must be controlled throughout the production cycle. This must include tolerance requirements for relevant stages of the manufacturing process that must be agreed with F4E TPO prior to commencement of manufacture.

[MRP3] Prior to contract commencement the supplier shall produce an implementation plan defining all quality related activities to be carried out during the contract. Elements relating to A&M must include:

- Reference standards
- Design change control procedures – Drawings and CAD models
- Document control
- Instrument calibrations and test procedures
- Control of nonconformities
- Data management procedures
- Measurement procedures- data acquisition, post processing and validation
- Reporting procedures

The Metrology Officer must be given the opportunity to review the implementation plan and any documents referenced within it, prior to contract commencement.

[MRP4] Inspections must be carried out at all crucial stages of the manufacturing process to guarantee adherence to final tolerances and set as early as possible corrective measures where necessary. The frequency and details of these inspections must be defined by the supplier in the Control Plan for the procurement which F4E will be given the opportunity to witness at their discretion.

[MRP5] The coordinate/datum system used during inspection and dimensional control processes must be as defined in the design drawings. Inspection reports must identify the nominal dimensions, applicable tolerances and the dimension achieved for the feature with non-complying values flagged in red on the report

[MRP6] All metrology equipment used for A&M tasks must be calibrated and controlled in accordance with subsection VIII.3. The equipment selected by the supplier must be fit for the requirements of the measurement process considering areas such as: process measurement uncertainty, speed of data acquisition, measurement geometry, local environmental conditions etc.

[MRP7] The supplier shall draft a Dimensional Inspection Plan (DIP) that must include all inputs and outputs relating to the measurement process, see section VIII. In particular, every classified measurement shall be univocally identified; see subsection VIII.11 for further guidance. The DIP must be supplied to F4E for acceptance, prior to commencement of manufacture

[MRP8] Process measurement uncertainty must be calculated for all reported measurements at a confidence level of 2σ . As a general rule, the uncertainty value must not exceed 20% of the tolerance applicable to the feature measured. If the uncertainty value exceeds this threshold, rules defined in ISO 14253-1:2013 shall apply. See subsection VIII.6 for the rationale behind these rules. Maintaining an uncertainty of 10% or less is recommended to optimise the available tolerance applicable to the feature concerned

[MRP9] The ITER Project drawings specify dimensions at the reference temperature of 20°C. Dimensional control for factory acceptance must be carried out in a controlled environment with a maximum temperature variation of $\pm 2^\circ\text{C}$. Key dimensions must be measured at the reference temperature or corrected to this temperature therefore

temperature stability during the measurement process is critical. Raw measurement data and corrected values must be made available to F4E.

Consideration must be given to the thermal inertia of the components being measured allowing sufficient soak time in the measurement environment to ensure thermal stabilisation. Temperature measurements must be recorded throughout the measurement task of both the component and the environment, logged against time and saved with the measurement file. The time interval between two consecutive temperature measurements must take into account the thermal stability of both the component and the environment, allowing to detect variations in the average temperature of the component of less than $\pm 1^{\circ}\text{C}$ and the development of thermal gradients. In any case, temperature must be measured and recorded at the beginning and at the end of the survey as well. For large components, multiple measurements must be required to enable the detection of thermal gradients. Temperature gradient and temperature variation with time must be treated as uncertainty sources and accounted for in the uncertainty budget of the measurement campaign.

- [MRP10] For measurement surveys utilising multiple instrument stations, bundle adjustment algorithms must be used to ensure error propagation, via multiple best-fit alignments, does not occur. In this case a periodic survey of the datum network will be performed to assess network stability.
- [MRP11] The supplier shall produce “as-built” drawings/3D models/electronic data in Catia V5 format.
- [MRP12] Deviations from the design requirements must be the subject of a nonconformity (NCR) report with corrective measures involving geometric or material property changes requiring the prior approval of F4E. To enable a decision to be made, the supplier shall furnish all documents justifying their proposal delivered within the NCR system.
- [MRP13] All inspection/dimensional control reports must include, as a minimum, the following information:
- Identification of measuring instruments used including calibration certificate reference;
 - (applicable only for A&M Class 1) Identification of ancillary equipment, as applicable, used including type, make unique identifier and calibration certificate number.i.e.
 - Test unit
 - Probes (dimensions, frequencies)
 - Targets and tooling
 - Scale bars
 - Identification of the part examined;
 - Reference drawing or CAD model identification defining the tolerances, datum etc. which the part has been inspected to, including issue status;
 - Time and place of the inspection plus signature of the operator;
 - Name and qualification of the operator and the employer;
 - Procedure followed and issue status;
 - (applicable only for A&M Class 1) Part temperature and time record;

- (applicable only for A&M Class 1) Meteorological data (temperature, humidity, pressure) and time record;
- (applicable for A&M Class 1 and Class 2) Results of instrument stability checks (see subsection VIII.1);
- Identification of all computer files generated during the inspection, all raw and processed data must be in a format acceptable to the F4E;
- Written values tabulated to provide: nominal dimensions, applicable tolerances and the dimension achieved for the feature, with non-complying values flagged in red on the report. Graphical data may be used if agreed by F4E.
- Interpretation of results, including an explanation for any readings considered invalid;
- Identification of any nonconformity reports raised.

In order to avoid unnecessary duplication, some of the information listed above can be provided in documents identified by the supplier and attached to the report.

III.5. Mandatory Requirements Procurement (MRP) for A&M Class 2 Activities

(a) Components or assemblies with an A&M class 2 for procurement will require a significant amount of dimensional control during manufacture, overseen by F4E. They may need to go through a pre-alignment process to provide references (fiducials) for assembly/installation at the ITER site and may also need some form of inspection during factory acceptance or on receipt by the TPO.

(b) The TPO for the system involved shall need to consider the level of control to be applied during the procurement process and identify the mandatory requirements in the technical specification applicable to the procurement.

(c) As a minimum the following mandatory requirements from A&M class 1 must be applied: [MRP1], [MRP2], [MRP3], [MRP4], [MRP5], [MRP6], [MRP7], [MRP10], [MRP12] and [MRP13]. Other requirements may be added at the discretion of the TPO.

III.6. Mandatory Requirements for Procurement (MRP) A&M Class 3 Activities

A&M class 3 activities only require setting out points/lines to facilitate their installation therefore the mandatory requirements for these activities are [MRP4], [MRP7], [MRP10] and [MRP13].

Note:

Unclassified measurements require no specific dimensional controls of alignment activities during the procurement process.

III.7. Summary of Mandatory Requirements for Procurement

The Table 1 resumes the applicability of mandatory requirements.

MRP	Class1	Class 2	Class 3	Unclassified
1	X	X		
2	X	X		
3	X	X		
4	X	X	X	
5	X	X		
6	X	X		
7	X	X	X	
8	X			
9	X			
10	X	X	X	
11	X			
12	X	X		
13¹	X	X	X	

Table 1 Mandatory Requirements

¹ For details on applicability of reporting requirements, see [MRP13]

IV. Standards

(a) There are a large number of standards relating to dimensional metrology which can broadly be grouped under the scope of two Technical Committees within the International Standards Organisation (ISO) namely

[TC 213 - Dimensional and geometrical product specifications and verification.](#)

Standardisation in the field of geometrical product specifications (GPS), i.e. macro- and micro geometry specifications covering dimensional and geometrical tolerance, surface properties and the related verification principles, measuring equipment and calibration requirements including the uncertainty of dimensional and geometrical measurement. The standardisation includes the basic layout and explanation of drawing indications (symbols).

[TC 176 - Quality management and quality assurance](#)

Standardization in the field of quality management (generic quality management systems and supporting technologies), as well as quality management standardization in specific sectors at the request of the affected sector and the ISO Technical Management Board.

[ISO/IEC Guide 98-3:2008\(E\) Guide to the Expression of uncertainty in measurement \(GUM:1995\)](#)

Standardization in the field of measurement uncertainty calculation and representation

Note:

ISO/TC 176 is also entrusted with an advisory function to all ISO and IEC technical committees to ensure the integrity of the generic quality system standards and the effective implementation of the ISO/IEC sector policy on quality management systems deliverables.

(b) Non ISO standards useful for reference:

[Guidelines for the Evaluation of Dimensional Measurement Uncertainty \(Technical Report\) \(B89.7.3.2 - 2007\)](#)

[Performance Evaluation of Laser-Based Spherical Coordinate Measurement Systems \(B89.4.19 - 2006\)](#)

V. Infrastructure - Survey Networks and Datum

(a) All measurement tasks need a fixed reference base (the datum) from which measurements can be made and calculated. For large volume metrology (LVM) applications this reference typically takes the form of a survey network consisting of a collection of target nests and/or instrument stations of known geometry and computed process measurement uncertainty.

(b) The accuracy and precision of the survey network(s) directly affects the measurement accuracy that can be achieved for subsequent alignment tasks. Accuracy and precision are terms that often get confused therefore for the purposes of this document their definitions are as follows:

Accuracy: The degree of conformity of a measured or calculated quantity to its actual (true) value

Precision: The degree of repeatability achieved when the same quantity is measured a number of times

(c) The survey network design process starts with a specification detailing how the network will be utilised and defining the ultimate measurement tolerances to be achieved. A perfect measurement does not exist, therefore it is important to be able to determine the measurement uncertainty for each stage of the measurement process and thus create a tolerance budget.

Measurement uncertainty: The parameter, associated with the result of a measurement (e.g. a calibration or test) that defines the range of values that could reasonably be attributed to the measured quantity. When uncertainty is evaluated and reported in a specified way it indicates the level of confidence that the value actually lies within the range defined by the uncertainty interval.

(d) The survey networks for the ITER Project will cover the whole of the site, providing a global coordinate matrix for survey instruments to reference against. The accuracy requirements for each network will vary, dependent on the alignment tasks for which they are being supplied. As such, interface control documents need to clearly define the alignment requirements of ITER Project components, assemblies and systems.

V.1. Primary Survey Network

(a) The first survey network installed was the Primary Survey network which defines the site reference system for buildings construction, provides the datum for monitoring stability and is the global datum for dedicated secondary networks installed throughout the site.

(b) The network consists of a collection of geodetic pillars, spread around the site and tied into foundations designed to optimise stability. A common interface for force-centring survey instruments and survey targets is embedded in the top of each pillar.

(c) A least squares adjustment was made to optimise the network and determine the co-ordinate and uncertainty values for each survey monument. The measurement uncertainty for the network was calculated to be ~1 mm when initially measured (summer of 2010). The network will be periodically monitored for stability.

(d) The coordinates of the primary survey network are reported within the Lambert III mapping projection with elevations relative to sea level. The Tokamak Global Coordinate System (TGCS) is an orthogonal system with the gravity vector defining the Z-axis at machine centre, the Y-axis points towards site north (37° counter-clockwise from geographic north) with the X-axis mutually perpendicular to Z & Y in an easterly direction. The origin of the coordinate system is at the nominal tokamak centre. Further information on ITER Project co-ordinate systems can be found in the ITER Project coordinate systems [4].

V.2. Tokamak Pit Network

(a) Machine assembly activities within the Tokamak pit must require accurate and precise alignment of components. The design specification for the network is to achieve an uncertainty no greater than ± 0.2 mm within a temperature controlled environment of $\pm 2^\circ\text{C}$ [3], this requirement is achievable if the environment remains stable. However, it is clear that with the immense transfer of loads occurring during construction that the network will move and distort to a certain extent. This distortion will need to be monitored and modelled during machine assembly to ensure that the final machine is aligned to specification. Both dynamic and passive measurement systems are being considered to provide an efficient system for monitoring the network movement and thus enable adjustments to be calculated and employed.

(b) The initial network must consist of many targets, or target nests, distributed around the pit wall covering the full height of the pit and extending into the adjacent port cells. The best fit centre of the pit must be derived from the pit wall targets defining the vertical datum axis for machine assembly. The datum for toroidal position and elevation will be derived from the best fit position of the port cells.

(c) Once the lower cryostat cylinder is installed, lines of sight to the lower pit wall targets will be blocked, however, lines of sight from the pit into the port cells and vice versa must be maintained. The pit wall targets above the cryostat lower cylinder must remain visible throughout the vacuum vessel construction, only becoming obscured when the cryostat upper cylinder is installed. The port cell targets are very important to the pit network as they provide the link to systems external to the pit within the adjacent galleries.

(d) It is likely that a number of different instrument types will be used during the Tokamak build process such as photogrammetry cameras, laser trackers and total stations. Laser trackers and total stations measure to similar Spherically Mounted Reflectors (SMR) or Corner Cube Reflectors (CCR), different names for the same item. Photogrammetry uses retro-reflective however, common targeting mounts are readily available from suppliers such as Hubbs and Brunson enabling interchangeability of instruments using the network.

V.3. Tokamak Galleries Networks

(a) Survey networks must be installed external to the bio-shield wall within the port cells and galleries. These multi-level networks must provide the dimensional control for all systems external to the Tokamak pit within the Tokamak building and will be linked to the Tokamak Pit Network via the port cells. The network must consist of a collection of wall and floor mounted target nests distributed throughout the galleries. These will be a standardised design as used for the pit network thus allowing flexibility of instrument selection for measurement tasks.

(b) Provision must be made to link the tokamak hall network to the primary network. This will be carried out with a total station and level and will be periodically checked for stability whilst lines of sight remain available.

V.4. Generic Buildings Networks

(a) There are various buildings around the site having different requirements for dimensional control. Users of these buildings need to consider their requirements at an early stage so that fit for purpose networks can be installed and measured in a timely manner.

(b) Where required, building networks must be linked to the primary survey network thus providing a global position for all setting out, alignment and measurement tasks. Where a local reference is required co-ordinate transformations into the building co-ordinate system can be made [4].

V.5. Assembly Datum

(a) During assembly of the ITER machine it will be necessary to adjust the build datum to optimise the assembly process with respect to the as-built geometry of key machine components. Each build datum must define the position and orientation of a coordinate frame within which the coordinates of the targets/target nests of the Tokamak Pit Network must be valued.

(b) The Pit Datum (PIT) as described in [section V.2](#) will be the initial datum used to align the following components:

- (i) Cryostat Column Baseplates
- (ii) Cryostat Columns
- (iii) Cryostat Base Section assembly

(c) The as-built position of the cryostat base must be used to define the Cryostat Base Datum (CBD) this must be used to align:

- (i) Cryostat lower Cylinder
- (ii) TF Coils

(d) The key characteristics on the cryostat base that are used to establish the CBD are the gravity support interfaces for both the TF coils (TFGS) and the vacuum vessel (VVGs).

(e) The key characteristic of the coils to be aligned is the current centre line (CCL) of the winding back, its position defined with respect to fiducials on the coil case.

(f) When the 18 TF Coils are in place, the Tokamak Assembly Datum (TAD) must be established representing the Least Square best Fit of the 18 TF Coils. This datum must be used for final alignment of the vacuum vessel, remaining magnet systems and the internal vacuum vessel components.

VI. Survey and Alignment During Buildings Construction

(a) During the construction phase of the ITER buildings there will be many requirements for accurate alignment. TPOs need to carefully consider the alignment requirements of their systems especially in areas of restricted access where opportunities to define reference points may be limited.

(b) The alignment path of systems that will ultimately be separated by physical barriers, such as concrete walls, may not be restricted at an early stage of the project. Providing the alignment references at this early stage may be the only opportunity to carry out the task and therefore guarantee the success of the installation.

(c) Some large or heavy pieces of plant and equipment may have to be installed during the construction process if access to deliver such component will not be possible once construction is complete. In these instances, alignment references will need to be established in advance to facilitate the setting out and alignment as required.

(d) Generally speaking; if a piece of equipment needs to be installed accurately to a global co-ordinate i.e. not positioned to local features like adjacent walls, building columns etc., then access to a survey network or pre-defined and established reference points will be required. Local alignment tasks need clear lines of sight or a network or dedicated reference points to facilitate the task.

(e) The installation of the primary survey network is complete however the addition, pace and sequence of secondary networks will be driven by the requirements defined by the various system TPOs on the project and should be clearly defined in the project schedule.

VII. Design for Alignment and Metrology

(a) The ITER machine is made up of many complex components and assemblies which need to interact in specific ways for the experiment to be successful. The design process will identify the optimum configuration for these systems identifying key characteristics to be focussed on with realistic parameters for manufacture and assembly, achieving a fit for purpose design.

(b) From a metrology perspective, measurement uncertainty is a key contributor to the overall tolerance budget and as such needs to be carefully considered. For example; if a component can be manufactured to a perceived tolerance of +/- 1 mm but the measurement process can only deliver to +/- 2 mm then the overall process is clearly out of control.

(c) It has already been identified that survey networks can be designed and installed to provide the datum for alignment activities. This however is only part of the requirement; the components themselves also need to be equipped with alignment features, designed to interface with the most appropriate measurement instruments and positioned to deliver the required alignment accuracy. In addition, the survey features need to be positioned with due consideration to the kinematics of the alignment system. There is no point in having an accurate and precise measurement system if the alignment mechanism cannot respond efficiently to the data provided by the measurement survey.

(d) The list below identifies areas for consideration when designing components for alignment:

<p>Alignment tolerances</p> <ul style="list-style-type: none"> • Position • Elevation • Angle: Roll, Pitch, • Yaw 	<p>Datum references</p> <ul style="list-style-type: none"> • PIT • CBD • TAD • Local to component 	<p>Alignment features</p> <ul style="list-style-type: none"> • Target nests • Tooling Ball • Retro reflective targets • Scribed reference lines
<p>Adjustment Mechanisms</p> <ul style="list-style-type: none"> • Screw threads • Jacks • Cams 	<p>Alignment Geometry</p> <ul style="list-style-type: none"> • Plane • Line • Centre of rotation • Coupled or decoupled 	<p>Metrology Instruments</p> <ul style="list-style-type: none"> • Laser Trackers • Total Stations • Theodolites • Articulated measurement arms • Photogrammetry • Laser Scanners • Levels

(e) During the design and planning stages for the ITER project and in support of the procurement contracts, the F4E Metrology Officer is available to give advice on aspects relating to geometrical and dimensional control for the project. Inspection and alignment surveys can be simulated at the design stage enabling qualification of measurement processes and the determination of uncertainty values for measured points and features within the survey.

VIII. Process Control and Best Practice

(a) The control of dimensional measurement is an essential part of the supply chain for the ITER Project components and the subsequent assembly activities to be carried out at the ITER site. For all critical inspections/surveys the measurement process needs to be clearly defined, controlled and accepted by F4E.

(b) Inputs to the process may include:

- (i) design specifications, drawings, CAD models, metrology drawings
- (ii) quality plans, procedures, method statements
- (iii) measuring instruments, calibrations, reference artefacts
- (iv) components and assemblies
- (v) plant and equipment
- (vi) personnel, skills, training
- (vii) computer software, simulations, uncertainty analysis
- (viii) standards

(c) With outputs such as:

- (i) raw measurement data
- (ii) Meteorological corrections
- (iii) Scale adjustments
- (iv) co-ordinate frame transforms
- (v) quality control inspection reports
- (vi) best-fit analyses and transformation matrices
- (vii) aligned component / assemblies
- (viii) fiducially referenced components / assemblies
- (ix) survey uncertainty analyses
- (x) signed off method statements, procedures, quality plans
- (xi) Survey Report

(d) The measurement process needs to be fit for purpose; delivering the required outputs in an efficient manner and providing assurances that the process is under control. F4E must be given the opportunity to review the process documentation prior to commencement and to witness inspections/surveys during manufacture, hold points must be specified in the Control Plan as required. In exceptional circumstances F4E reserves the right to carry out its own dimensional control measurements using its own personnel or a third party supplier.

(e) F4E TPO will identify key interfaces which must be inspected during manufacture and monitored during assembly operations, such as welding, which may affect the fit, form or function of the assembly. The control of such operations must be clearly defined in the process documentation with measurement data recorded in an appropriate format.

VIII.1. Large Volume Portable Measurement Systems

(a) For large volume metrology it is often necessary to bring the measuring instrument to the job. Portable co-ordinate measurement systems such as Laser scanners, Laser trackers, total stations, theodolites and photogrammetry, enable the surveyor/inspector to carry out the measurement task in the workplace however, with this flexibility comes added variables that must to be controlled.

(b) The workshop environment is unlikely to be as rigorously controlled as a dedicated metrology laboratory. Changes in temperature, humidity and pressure all contribute to measurement variance and therefore need to be recorded and compensated for.

(c) Measuring a large component or assembly will often require the use of multiple instrument stations. This may be due to line of sight constraints or as a means of reducing observation lengths within the survey to minimise measurement uncertainty. Whatever the reason, if the results are to be considered within a single coordinate system then a network solution to the fit will be required. Best practice is to carry out a bundle adjustment of the network; this iterative process will optimise the network by minimising the combined pointing errors of the measurements. With the instrument stations optimised the uncertainty of the measured points within the network can be calculated through a variance algorithm.

(d) The measurement survey session shall be validated by a drift check. It is recommended not to exceed two hours between two consecutive drift checks. Minimising the potential for error will come from a good understanding of the technical specification, consideration and compensation for the working environment and by applying best practice processes.

VIII.2. Best-fit Analysis and Alignment Transformations

(a) Initial measurements taken during a survey will be valued within the measuring instrument's local co-ordinate system. Their relationship to each other will be clearly defined but they will require aligning to the part or assembly to which they relate.

(b) The alignment can be defined by geometry measured within the measurement session i.e. points, lines and planes or by referencing measured points to features within the CAD model such as faces, surfaces etc.

(c) Unlike the CAD model, the measured points will not fit perfectly to the design nominal therefore a series of weighted best-fits will need to be applied to optimise the alignment. The key characteristics to be used for the alignment and their importance shall be proposed by the supplier and reviewed by F4E. This information shall either be provided within engineering drawings, annotated to the CAD model or as written instructions.

(d) The supplier's measurement procedure must identify best fit processes to be carried out including any data filtering that will be applied. In general, all raw data must be maintained and stored for ease of recall and review by F4E.

VIII.3. Control of Inspection Measurement and Test Equipment

(a) All measuring equipment must be fit for purpose to deliver to the tolerances specified. A documented calibration system must be in operation traceable to national standards and certificated through an accredited body. A calibration schedule must be in place with all calibrations logged within a register and all calibration certificates filed for ease of recall.

(b) All fixed-volume CMMs and large volume portable measurement systems must be calibrated at least once a year and hold a current calibration certificate issued by either:

- An accredited laboratory (EN ISO/IEC 17025:2005), or

- An authorized service center. The service center shall hold a current authorization certificate issued by the manufacturer of the equipment clearly stating expiry date, and a certificate of approval of the company's Quality Management System to ISO 9001 for the scope of equipment service and calibration.

(c) For all other equipment, the calibration requirements may vary according to the class of activities in which they are used:

- Equipment used in A&M Class 1, Class 2 activities must be calibrated at least once a year and hold a current calibration certificate issued by an accredited laboratory (EN ISO/IEC 17025:2005)
- Equipment used in A&M Class 3 activities must be verified at least once a year using a "master instrument" calibrated according to the previous bullet or the previous subparagraph (b). A verification report shall be produced, ensuring metrological traceability to a certified reference through an unbroken chain of calibrations, each one having stated uncertainty. If this approach is deemed unpractical, the equipment can be calibrated according to the previous bullet.

(d) A Quality document must clearly identify where and when measurement equipment has been used. Each piece of equipment must be uniquely identified and must only be used when its calibration status is within date.

(e) For critical measurements it may be necessary to calibrate a measuring instrument more frequently than the suppliers recommended interval. Where F4E deems this necessary it will mark up the quality plan accordingly.

VIII.4. Coordinate Systems and Measurement Units

(a) In general, when conveying results of a survey/inspection the co-ordinate system used must be coincident and of the same type as that used to specify the design. The measurement units must be as defined in the drawing or model and the deviation from nominal of the as-built dimensions must be reported in the same manner as they are toleranced.

(b) Results from an inspection must be expressed in quantitative terms when a design characteristic is expressed in numerical units. Attribute data may be used (e.g. go/no-go) if no inspection technique resulting in a quantitative measurement is feasible. Where this is the case the gauge used for the process must be calibrated according to subsection VIII.3, paragraph (c).

VIII.5. Metrology Software and Data Formats

The ITER Project adopted *Spatial Analyzer* (SA), supplied by *New River Kinematics* (NRK)/Hexagon Manufacturing Intelligence, as its preferred metrology software. The software interfaces with the vast majority of measurement instruments; its architecture maintains full traceability of the measurement process storing all raw measurement data and environmental monitoring corrections. In order to maintain project consistency SA latest and last but one versions have to be used only.

(a) The software has been specifically designed for large volume metrology applications; its optimisation algorithms for network configurations, computes measurement uncertainty by default and analyses instrument performance in the process. The system can be used offline for measurement simulations by utilising constructed geometry within the application or by directly importing Catia V5 models, complete with embedded GD&T if required.

(b) F4E does not prescribe which software should be used however; it is critical that measurement data can be easily transferred between the parties of the ITER Project. During manufacture this data may be required to qualify measurement processes, address non-conformance issues, and consider concession requests and certainly to build up as-built models of the supply.

(c) The following data formats can be read into SA:

ASCII, STEP, IGES, VDA, SAT, DMIS, AIMS-TDF, Polyworks (POL, PIF, PF, DPI), Direct Catia V4 V5 *.CGR process, Direct UG process, Direct ProE process, VSTARS .xyz file, VSTARS Cameras (outstar.txt), xyz ijk File (IJK), Digital network levels, IMETRIC, 1-D data (Datamyte)

(d) In all cases measurement data must include uncertainty values.

VIII.6. Measurement Uncertainty

(a) Measurement uncertainty is the parameter, associated with the result of a measurement (e.g. a calibration or test) that defines the range of values that could reasonably be attributed to the measured quantity. When uncertainty is evaluated and reported in a specified way it indicates the level of confidence that the value actually lies within the range defined by the uncertainty interval.

(b) No measurement is complete unless its uncertainty can be quantified. In a similar way that a tolerance relays the acceptance specification for a given dimension, the measurement uncertainty must be considered when determining whether a measured characteristic meets the design criteria.

For Example:

If the distance between 2 points is required to be 10 m \pm 0.003 m then a measurement returning a value of 10.0025 m appears to be acceptable however; if the measurement uncertainty for each point is \pm 0.001 m then the reality is that the measured dimension could be out of spec by up to 0.0015 m. Figure VIII.1 demonstrates this pictorially

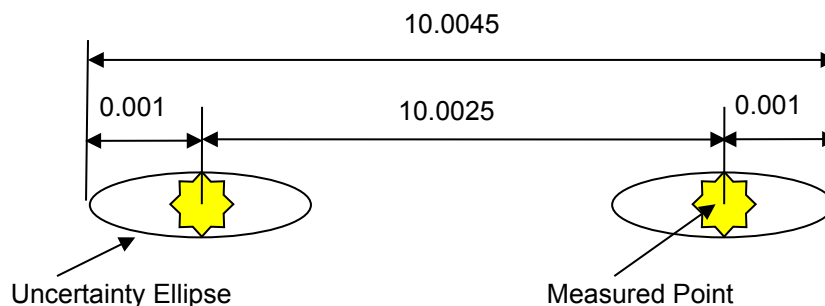

Figure VIII.1: example of an uncertainty analysis for a linear dimension

VIII.7. Measurement Scale

(a) Components for the ITER machine are dimensioned nominally at 20°C. For large objects the effects of temperature change on the physical size of the object can be considerable and as such must be taken into account during the measurement process.

(b) Measurements, especially those carried out over a prolonged period, must be carried out in thermally stable conditions. The measuring instrument and component must be given time to acclimatise to the environment and the temperature must be monitored throughout the measurement task.

(c) Where the measurements cannot be taken at 20°C a scale factor will need to be applied to the measurement job and clearly stated in the measurement report. In consideration of the components

orientation and fixturing, the scaling process must be identified in the measurement procedure for acceptance by F4E.

(d) While the effect of a uniform change in a component's temperature can be managed by applying a scale factor to the measurements, the effects of a temperature gradient across the component are more difficult to predict and to compensate for. A reasonable approach to take into account temperature gradients, in the majority of cases, would be to consider them as contributors to the uncertainty budget associated to the measurements. Such an approach is exemplified in [10].

(e) When using optical measuring systems such as laser trackers or total stations consideration needs to be given to distance measurements from these instrument's interferometers or absolute distance meters. Environmental factors such as changes in atmospheric pressure, temperature and humidity will affect the wavelength and as such need to be corrected. All environmental monitors used for this process must be calibrated in line with the manufactures recommendations and traceable to national standards.

(f) Intersecting theodolite systems and photogrammetry rely on defined calibrated length measurements to scale the measurement job. Scale bars, interferometer measured distances or a controlled and traceable network of stable points can all be used to introduce scale. The important factor is that the scale system is controlled, is representative to the size/material of component to be measured and traceable.

VIII.8. Component Orientation and Fixturing for Measurement

(a) There are many large and heavy components which are assembled together to make the ITER machine. These components will distort to varying degrees depending on how they are supported during manufacture and assembly therefore it is essential that these parameters are considered and clearly defined within the measurement procedure.

(b) Where a component is to be supported, machined and inspected in one orientation but put into service in another, the effects of the transformation need to be established.

(c) By default, CAD models describe a components shape and size in a state of equilibrium, unaffected by external influences such as gravity. Computer aided manufacturing and inspection systems often use the CAD model to drive the manufacturing and inspection processes therefore the CAD model either needs be morphed to reflect the geometric condition for inspection or offset values need to be supplied for the specific areas of interest. A process to obtain the offset values to compensate for the effects of loads is proposed in [11].

VIII.9. Fiducialisation

(a) Fiducialisation is the process used to define reference points (fiducials) on a component or assembly with respect to a reference coordinate frame. The position and orientation of the frame is constructed from as-built measurement data and reflects the optimum alignment achievable from the data set measured.

(b) To define an object's 3D position and orientation, a minimum of 3 fiducials are required however, utilising more fiducials will add redundancy to the survey and provide a better representation of the measurement volume. The quantity and position of the fiducials will be driven by the design specification and qualified through tolerance assessment and uncertainty analysis.

(c) Where fiducials are required to facilitate an alignment at the ITER site, their design, position and orientation will be defined by the ITER Project. Fiducials used by the supplier must either be permanently attached to the object or fitted temporarily during the measurement via a standard interface as described in section VIII.10.

(d) Each fiducial must have a permanent identifier marked or punched (when appropriate) on a visible surface.

VIII.10. Targets and Tooling

(a) Laser trackers and total stations measure to similar spherical targets called SMR retro reflectors or corner cubes. Photogrammetry also uses retro reflective targets but of a different type however, interchangeable targeting mounts are readily available.

(b) A typical interface for these mounts could be an H7 hole of diameter 6, 8, or 10 mm reamed perpendicular into a reference face. The important thing to note is that whilst the mount will position the target coincident with the axis of the hole, the target will be offset from the reference face by a defined amount.

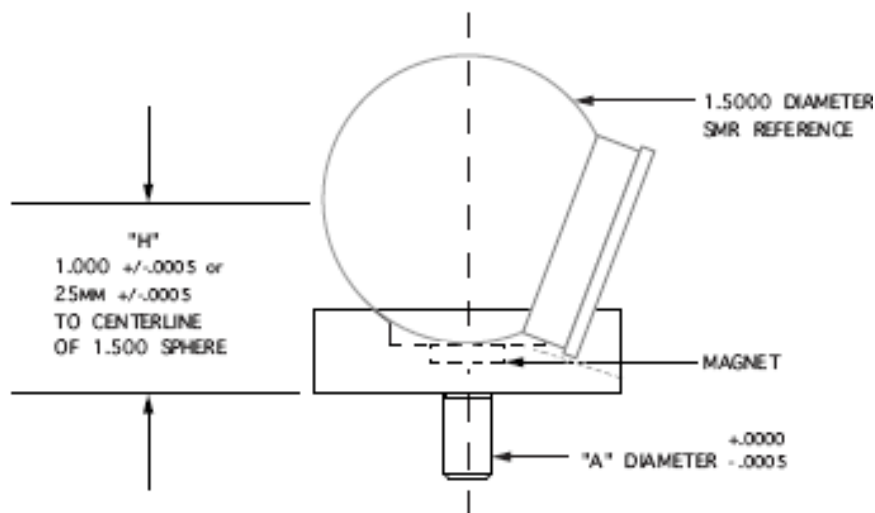

Fig. VIII.2 Example of an SMR mounted in a pin nest

(c) The example above shows a laser tracker SMR retro reflector mounted within a target mount. Dimension "H" identifies the offset applied and the manufacturing tolerance.

(d) All targeting mounts or generically speaking tooling, that contributes to the measurement process must be controlled within the supplier's calibration system and must be uniquely identified. The measurement process must specifically record when such tooling has been used defining the offset applied and its direction.

VIII.11. Identification of metrology requirements

- In general, the specifications required for metrology-related activities are different from the ones required for other procurement or site activities. Therefore, it is advisable to identify the metrology requirements in dedicated documents. This could be done in two ways: By issuing a specific set of drawings/3D models dedicated to the definition of metrology requirements, i.e. the geometric and dimensional specifications to be measured, or
- By adding appropriate annotations to the existing drawing/3D models that shall clearly define the metrology classification.

Either way, the requirements shall be univocally identified and classified in accordance with section II.

IX. Coordination for Metrology Activities

(a) Many of the components for the ITER machine have extremely demanding tolerances with respect to alignment and dimensional control. Their installation locations are often very constrained

and their large size makes adjustment all the more difficult. These components may be standalone items or an embodiment of constituent parts combined to deliver a specific function. Whatever the requirement, if metrology is a contributor then it is an interface that needs to be resourced and managed.

(b) The F4E Metrology Officer is available to give technical advice during the design phase of the project and is tasked to put in place and manage the requisite infrastructure to support the machine build and its associated systems. This will include the design and realisation of survey networks (section V) development of alignment strategies, procurement of equipment and the day to day management of the metrology team.

(c) The F4E metrology team is put together to support the programmed metrology requirements of the ITER project therefore it is important that these needs are identified as early as possible to optimise the resourcing with respect to equipment and personnel.

IX.1. Interface Control

(a) TPO for components, assemblies and systems requiring support from the F4E metrology team must specify their requirements in an appropriate technical document

(b) Typical details required must include:

- (i) General description of the measurement task detailing processes and required outputs
- (ii) Reference datum systems to be used i.e. site primary datum system, pit datum system, locally defined system etc.
- (iii) Tolerance requirements for dimensional control and or alignment i.e. position angularity, elevation, level etc.
- (iv) Fiducialisation requirements (section [VIII.9](#))
- (v) Location where the survey / inspection is to be carried out
- (vi) Scheduled date for the task and sub-tasks
- (vii) State of plant during the task(s); component orientation, supporting structures, scaffolding, adjacent work activities etc.
- (viii) Environmental controls envisaged during the survey

(c) From the above information the Metrology Officer will elaborate a measurement plan, detailing the work scope, equipment and tooling requirements, estimated task duration and manpower allocation. Any inputs required from the customer such as drawings, CAD models etc. will be identified and their required delivery dates included in the metrology schedule.

IX.2. Design Reviews

(a) Alignment and metrology requirements and processes will typically be reviewed at the design reviews for the system to which they apply. Design reviews will be carried out in accordance with F4E Design Review Procedure [5].

(b) The conceptual design review must demonstrate that the alignment requirements and tolerances for the system under review have been identified and included in the Design Compliance Matrix (DCM). Specific details must be included in the interface sheet of the appropriate interface control document as they are developed and must be in place before the final design review.

(c) At the preliminary design review the outline processes for alignment should be presented to provide an overview of the scope of the task including an indicative schedule. At this time it should

be clear where responsibilities lie for the various stages of the installation within the ITER Project parties.

(d) Alignment and Metrology activities could include:

- (i) Goods inwards dimensional inspection of system components
- (ii) Fiducialisation of components for assembly (section [VIII.9](#))
- (iii) Provision of reference datum, network points, elevation lines (section [V](#))
- (iv) Setting out for enabling activities: marking out for location systems, stillage etc.
- (v) As-built reconstruction for customisation of interfaces
- (vi) Alignment of components: position, orientation, elevation....

(e) Following the preliminary design review the alignment and metrology processes will be elaborated by the officer(s) concerned. The level of elaboration will be dependent on a number of contributors such as the uniqueness of the task, the complexity of the process, access restrictions, required accuracy etc. The preliminary design review will define the scope of this elaboration which will subsequently identify the metrology input for the final design review.

(f) The final design review must demonstrate that dimensional control and alignment processes have been sufficiently addressed to ensure that the system under review can be successfully manufactured and subsequently installed at the ITER site. The Metrology Officer will use the metrology handbook as reference for the review process and the DCM to assess compliance with the design requirements, contributing to the overall acceptance process.

X. Quality and Documentation

All components, processes, documents and data within the scope of this handbook must be subject to the F4E QA Programme for the ITER Project [2] and the Supplier Quality Requirements [1].