



idm@F4E UID / VERSION

242DG5 / 1.7

VERSION CREATED ON / STATUS

12 September 2017 / Approved

EXTERNAL REFERENCE

F4E Document

F4E-QA-119 - Requirements Management & Verification (RMV) Requirements for F4E Suppliers

This document specifies the Requirements Management & Verification (RMV) requirements for F4E Suppliers.

<i>Approval Process</i>			
	<i>Name</i>	<i>Action</i>	<i>Affiliation</i>
<i>Author</i>	Serra G.	12 September 2017:signed	PM
<i>Co-Authors</i>			
<i>Reviewers</i>	Bruneel I.	13 September 2017:recommended (Fast Track)	ITERD
<i>Previous Versions</i>	Bénilan I.	02 July 2017:recommended v1.6	PM
<i>Reviews</i>	Puppin S.	26 July 2017:recommended v1.6	PM
	Rodrigues D.	04 July 2017:recommended v1.6	ADM
	Benet Ciurana J. M.	03 July 2017:recommended v1.6	ITERD
	Balague Serra S.	03 July 2017:recommended v1.6	ITERD
<i>Approver</i>	Baker K.	20 September 2017:approved	PM
<i>RO: Rodrigues Diogo (F4E)</i>			
<i>Read Access</i>	LG: F4E_QAO, AD: IDM_Users, GG: IAS Audit on Document Management, project administrator, RO, LG: RMV Team, LG: Expert, AD: IDM_F4E, AD: I-CONF-OBSOLETE, GG: IAC, LG: CryoTeam, LG: MITICA CRYOPLANT TEAM - EXTERNAL, LG: IRP MITICA Cryoplant, LG: NB-I&C-F4E, AD: F4E_Users, AD: F4EN-A80, AD: IDM DI-LS-P...		

Original Document MD5#: 10B53421650C8C07706C1E8C49166B3A

Change Log

F4E-QA-119 - Requirements Management & Verification (RMV) Requirements for F4E Suppliers (242DG5)

<i>Version</i>	<i>Latest Status</i>	<i>Issue Date</i>	<i>Description of Change</i>
v0.0	In Work	05 December 2014	
v1.0	Signed	19 December 2014	<p>First version.</p> <p>Document generated from DOORS 9.5.1 to Word 2010 with IRDRMFAO 6.1.0.3.</p> <p>Statistics: this version of the specification contains 15 Requirements and 4 Applicable Documents.</p>
v1.1	Signed	13 January 2015	<p>Comments from reviewers integrated:</p> <ul style="list-style-type: none"> • Title changed using the term "Suppliers" instead of "Subcontractors" • Different tabs in ADs mentioned • REQ-005 - Clarification and inclusion of PICs case and NSVCD • REQ-006 to REQ-010 were re-written in the active voice and re-organized by milestone to reduce the number of requirements (3 were deleted as included in existing ones). • The PUIDs of the requirements were renumbered since the document has not yet been approved nor released outside of F4E. • The PIC deliverable was identified as a requirement (REQ-011) • Some typos and terms were clarified <p>Document generated from DOORS 9.5.1 to Word 2010 with IRDRMFAO 6.1.0.3.</p> <p>Statistics: this version of the specification contains 13 Requirements and 4 Applicable Documents.</p>
v1.2	Signed	02 March 2015	<p>Comments from reviewers integrated:</p> <p>Information related to parent requirements removed from MS Word version</p> <p>AD-002 (VCD) deleted as covered by AD-003</p> <p>AD-004 (NSVCD) deleted</p> <p>1.2 - clarification on applicability of the requirements in this present specification</p> <p>3.1 - clarification added on meaning of REQ-001 (database)</p> <p>REQ-002 - "F4E" added when referring to F4E requirements</p> <p>REQ-004 (recursivity) deleted</p> <p>REQ-005 - reference to NSVCD removed as covered by VCD. Reference to AD-002 removed as covered by AD-003. Requirement updated to cover for REQ-013</p> <p>REQ-011 deleted</p> <p>REQ-013 deleted</p> <p>Statistics: this version of the specification contains 10 Requirements and 2 Applicable Documents.</p>
v1.3	Approved	09 March 2015	<p>Editorial comments from reviewers integrated:</p> <ul style="list-style-type: none"> - 2 typos - Naming convention of requirements updated - Deleted requirements have now been removed in order to have a clean version - QA-119 included in title of the document <p>Statistics: this version of the specification contains 10 Requirements and 2 Applicable Documents.</p>
v1.4	Signed	08 June 2017	<p>CMx (Compliance Matrix) replaced by RPM (Requirements Propagation Matrix)</p> <p>Chapter 4 added with Applicability Matrix explanation</p>
v1.5	Signed	09 June 2017	<p>1.§1.3: REQ-NNN replaced by RMV4S-REQ-NNN.</p> <p>2.REQ-002: "listed in the Tender" deleted (because the list of AD can evolve after the Tender).</p> <p>3.§3.2: insert an adaptation of slide 7 from RMV with Suppliers (224B3W v2.1).</p> <p>4.§3.2: Replace in Table 2 "Compliance Matrix (CMx)" by "Requirements Propagation Matrix (RPM)".</p> <p>5.§3.2: In DOORS source, for object containing the OLE object Table 2, set WEXP OLE Inline = true (to make the table searchable in the Word exported file).</p> <p>6.§4: In DOORS source, for object containing the OLE object Table 3, set WEXP OLE Inline = true (to make the table searchable in the Word exported file).</p> <p>7. reference to final ADP instead of ADP to avoid confusion with ADP</p>

			definition related to any deliverable.
v1.6	Signed	30 June 2017	Following comments from reviewers: Introduction to ITER Project removed §1.1: Clarification that this specification applies for technical requirements on the specimen/system.product Figures 1 & 2: slight correction
v1.7	Approved	12 September 2017	Sentence mentioning additional requirements for PIC components and corresponding PIAs listed in [RD-007] NSVCD acronym is now obsolete and has been removed QA-114 and QA-115 added as reference documents for more complete background information.



REQUIREMENTS MANAGEMENT & VERIFICATION (RMV) REQUIREMENTS FOR F4E SUPPLIERS (QA-119)

idm@F4E Reference:	F4E_D_242DG5 v1.7	Call No	
--------------------	-------------------	---------	--

ABSTRACT

This document specifies the Requirements Management & Verification (RMV) requirements for F4E Suppliers. It details the deliverables that F4E expects from its Suppliers in the frame of Design & manufacturing activities.

This document contributes to the propagation of the following requirements from RMV Business Requirements (25EJSZ): REQ-0011 & REQ-0025.

Statistics: this version of the specification contains **10 Requirements** (with Applicability=true) and **2 Applicable Documents** (with Applicability=true).

Template: F4E_D_25JV8T v2.9

Table of Contents

ABSTRACT	1
ACRONYMS, TERMS AND DEFINITIONS	3
APPLICABLE DOCUMENTS	3
REFERENCE DOCUMENTS	4
1 INTRODUCTION	5
1.1 SUBJECT OF THIS TECHNICAL SPECIFICATION	5
1.2 IDENTIFICATION OF REQUIREMENTS	5
2 SCOPE	6
3 RMV TECHNICAL REQUIREMENTS FOR SUPPLIERS	7
3.1 GENERAL REQUIREMENTS	7
3.2 RMV REQUIREMENTS FOR FORMAL DELIVERABLES	8
3.3 RMV REQUIREMENTS FOR INPUTS FOR F4E RMVDB	10
4 QA-119 REQUIREMENTS APPLICABILITY	11

List of Captions

Table 1: Acronyms, terms and definitions	3
Figure 1: RMVDB Data Model	8
Table 2: RMV deliverables	9
Figure 2: ITER Product Reviews Lifecycle	10
Table 3: QA-119 Applicability Matrix	11

ACRONYMS, TERMS AND DEFINITIONS

Acronym	Term	Definition
AD	Applicable Document	Document containing provisions that constitute mandatory requirements to the extent specified.
ADP	Acceptance Data Package	Is the documentation package linked with a deliverable to be submitted by the supplier
F4E	Fusion for Energy	The European Joint Undertaking for ITER and the Development of Fusion Energy
IO	ITER IO	ITER International Organisation, sometimes referred to as ITER
PIC	Protection Important Component	Component important for the protection of the interests mentioned in article L.593-1 of the french environment code
ReqIF	Requirements Interchange Format	XML file format that can be used to exchange requirements, along with its associated metadata, between software tools from different vendors
RMV	Requirements Management & Verification	Process to control and verify the requirements
RMVDB	Requirements Management & Verification Data Base	Database of requirements and verification activities
RPM	Requirements Propagation Matrix	Matrix showing the propagation of the requirements to the level below (replaces CMx)
SoCMx	Statement of Compliance matrix	Matrix where the tenderer/bidder commits its compliance in front of each requirement
VCD	Verification Control Document	Matrix showing in front of each requirement, how the requirement was or will be verified (test, analysis, engineering document, inspection).
VI	Verification Item	Verification effort produced in order to verify one or several requirements. Can be a test, an analysis, an engineering document or an inspection)

Table 1: Acronyms, terms and definitions

APPLICABLE DOCUMENTS

The following documents apply within the scope specified in the present specification depending on whether or not the F4E Supplier uses IBM Rational DOORS with the F4E Data Model or works in a different environment (different Requirements tool or IBM Rational DOORS with a different Data Model than the one used by F4E). With regard to the two options, the relevant documents here below will be mentioned in the present specification in the relevant option section.

Each one of the templates below contains several "tabs":

- Help - Where each field is explained
- Examples (one or more) - Where a small example is included

- Cover page
- The Matrix itself
- Additional tabs in some cases

<# AD-001

[F4E RMV template - RPM \(25K2BN\)](#)

#>

<# AD-002

[F4E RMV template - VCD Import - Excel-to-DOORS \(23NP7T\)](#)

#>

REFERENCE DOCUMENTS

Reference documents are intended to provide background and supplementary information. For any information related to the Requirements Management and Verification process, RD-001 contains the description as well as the relevant definitions of terms.

[RD-001]

[F4E Requirements Management & Verification Process Description \(25LTXW\)](#)

[RD-002]

[RMVDB UM "DOORS-to-Excel export" \(26GNKE\)](#)

[RD-003]

[RMVDB UM "Fill RPM in Excel" \(22NC3U\)](#)

[RD-004]

[RMVDB UM "Fill VCD in Excel" \(23SN72\)](#)

[RD-005]

[F4E RMV template - SoCMx \(25FD7V\)](#)

[RD-006]

[F4E-QA-113 - Propagation of Generic Safety Requirements in the F4E Supply Chain \(22JRQY\)](#)

[RD-007]

[F4E-QA-201 - Technical Specification Template - Annex B \(22EVAD\)](#)

[RD-008]

[F4E-QA-114 - Instructions for Suppliers Performing Design Analysis \(22FR5T\)](#)

[RD-009]

[F4E-QA-115 - Supplier Quality Requirements \(22F8BJ\)](#)

1 INTRODUCTION

1.1 Subject of this Technical Specification

This technical specification specifies the Requirements Management and Verification requirements for F4E Suppliers in the frame of technical requirements of any kind on the specimen/system/product (including Defined Requirements for PICs). It contains the default requirements for a typical design and manufacturing contract starting from a functional specification up to the fabrication of the specimen. The applicability of each one of these requirements is defined in the Annex B of the corresponding contract. This is because some of these requirements only apply to manufacturing contracts, some only apply to design contracts and some only apply to specific phases of a project.

In the case of PIC Components and corresponding PIAs, additional requirements to the present specification and to its application are listed in the [RD-007] - F4E-QA-113 - **Propagation of Generic Safety Requirements in the F4E Supply Chain** (22JRQY)

1.2 Identification of requirements

Each requirement in this specification is formally identified.

- A requirement unambiguously starts with a paragraph containing the string "<# " followed by the **requirement identifier** "RMV4S-REQ-NNN" where "N" is a number between 0 and 9.
- A requirement unambiguously ends with a paragraph containing the string "#>".

Clarifications to the requirements and other information are provided outside of the requirements.

2 SCOPE

This specification applies to Suppliers with F4E contracts which have design development and/or manufacturing activities of ITER components.

3 RMV TECHNICAL REQUIREMENTS FOR SUPPLIERS

3.1 General Requirements

<# RMV4S-REQ-001

The Supplier shall implement a Supplier Requirements Management & Verification Database (Supplier RMVDB) to record and trace all requirements having to be verified.

#>

By database, it is meant any kind of recording software to be able to trace the relationships between requirements of different PBS levels and between F4E requirements and verification efforts performed by the Supplier. As an example, for small quantity of requirements, MS Excel can be considered (see Applicable Documents).

The type of database is to be agreed with F4E, if not specified in the contract.

<# RMV4S-REQ-002

The Supplier RMVDB shall be used during all project phases to record:

- F4E requirements (from F4E Annex B Technical Specification and the subset of Applicable Documents listed),
- Supplier compliance status to these F4E requirements,
- Supplier requirements as flowed-down from F4E requirements,
- Traceability of engineering changes (deviation requests, Nonconformities that impact requirements, etc...) to the F4E requirements,
- Supplier Verification Plan containing Verification Items (VI) references,
- Traceability from Verification Items to the F4E requirements,
- Traceability of Verification status and results to the F4E requirements.
- Supplier verification close-out of F4E requirements,

#>

<# RMV4S-REQ-003

Ultimately the Supplier RMVDB shall be used to record the progress on planning and executing the verification efforts aimed at providing the evidence that F4E requirements are met through regular issues of both the Supplier Verification Control Document (VCD) and statistical dashboards.

#>

The description of the Requirements Management and Verification (RMV) process and all definitions can be found in Requirements Management & Verification Process Description (25LTXW) [RD-001].

The RMVDB data model is illustrated here below for information.

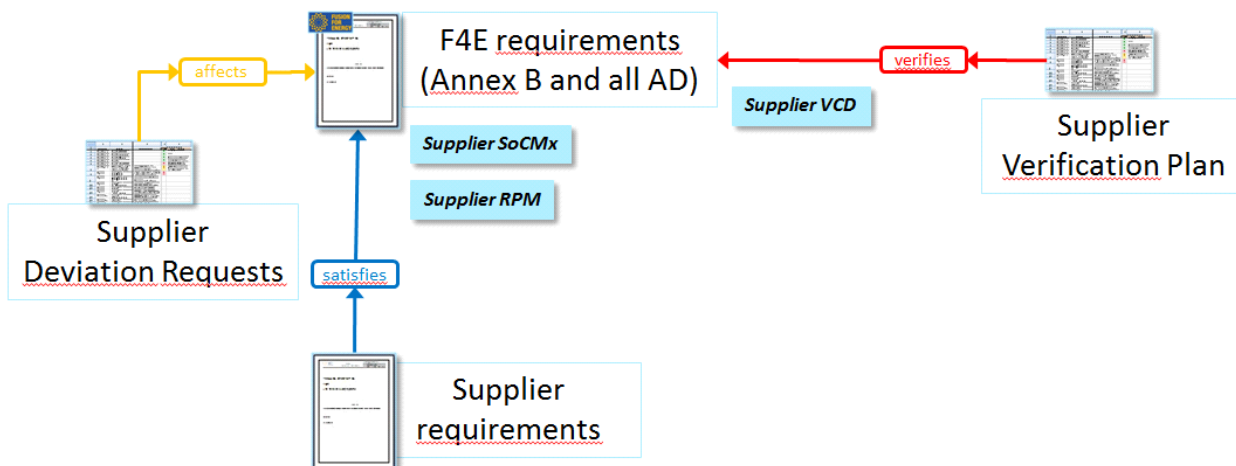

Figure 1: RMVDB Data Model

Deliverables:

F4E will indicate to the Supplier the list of applicable documents subject to RMV (documents that contain technical requirements for which the present specification applies). This list will be referred as the "Supplier RMV AD list"

The Statement of Compliance Matrix (SoCMx) in [RD-005] is normally requested with the offer in the Tender Specification.

The Supplier RMV deliverables will be used as inputs for the different Reviews (formal deliverables) and also to populate the F4E RMVDB in order to have the full requirements traceability and verification scheme in F4E RMVDB (see corresponding chapters below).

3.2 RMV Requirements for Formal Deliverables

<# RMV4S-REQ-004

In order to be able to load the Supplier RMV deliverables into F4E RMVDB, whenever applicable as stated in the contract annex B, the supplier shall provide the RPMs and the VCDs in accordance with the templates in [AD-001] and [AD-002], in MS Excel. The Supplier can nevertheless agree with F4E an alternative format using for example DOORS Module Archive and DOORS Project Archive or ReqIF format.

#>

<# RMV4S-REQ-005

The Supplier shall deliver a set of Requirements Propagation Matrices (RPMs) and a set of Qualification Stage Verification Control Documents (VCDs) on the RMV AD list documents at the Preliminary Design Review (PDR).

#>

<# RMV4S-REQ-006

The Supplier shall deliver a set of final Requirements Propagation Matrices (RPMs), a set of Qualification Stage Verification Control Documents (VCDs) and a set of Acceptance Stage Verification Control Documents (VCDs) on the RMV AD list documents at the Final Design Review (FDR).

#>

<# RMV4S-REQ-007

The Supplier shall deliver a set of Qualification Stage Verification Control Documents (VCDs) and a set of Acceptance Stage Verification Control Documents (VCDs) on the RMV AD list documents at the Manufacturing Readiness Review (MRR).

#>

<# RMV4S-REQ-008

The Supplier shall deliver a set of Acceptance Stage Verification Control Documents (VCDs) on the RMV AD list documents at the Manufacturing Readiness Review (MRR).

#>

<# RMV4S-REQ-009

The Supplier shall deliver a set of Acceptance Stage Verification Control Documents (VCDs) on the RMV AD list documents with the final Acceptance Data Package (ADP).

#>

The deliverables maturity is given here as an indication in the following table (in accordance with Figure 2 logic):

TIMING OF SUBMISSION	REQUIRED SUBMISSION
In Preliminary Design Review Data Package	<ul style="list-style-type: none"> • Requirements Propagation Matrix (RPM) – 90% covered • Qualification Verification Control Document (VCD) - preliminary
In Final Design Review Data Package	<ul style="list-style-type: none"> • Requirements Propagation Matrix (RPM) (100% covered) • Qualification Verification Control Document (VCD) 90% complete • Acceptance Verification Control Document (VCD) - preliminary
In Manufacturing Readiness Review Data Package	<ul style="list-style-type: none"> • Qualification Verification Control Document (VCD) - 100% complete) • Acceptance Verification Control Document (VCD) – Verification on final specimen 100% identified
At Product Acceptance	<ul style="list-style-type: none"> • Acceptance Verification Control Document (VCD) - Verification on final specimen 100% complete)

Table 2: RMV deliverables

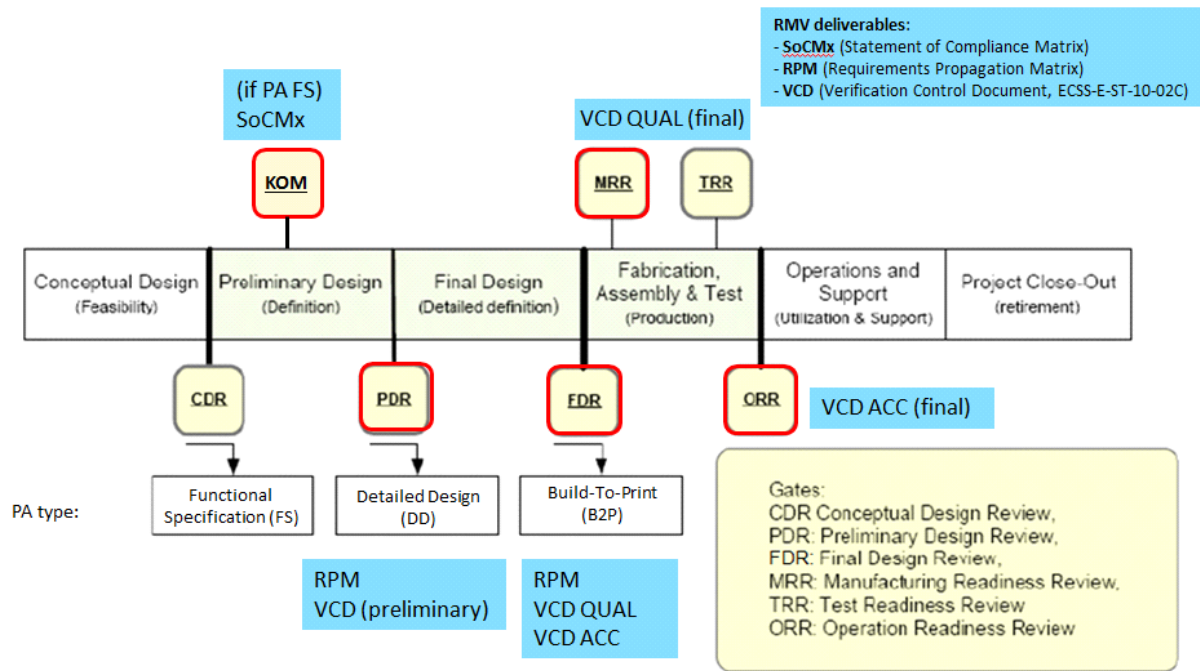

Figure 2: ITER Product Reviews Lifecycle

3.3 RMV Requirements for inputs for F4E RMVDB

<# RMV4S-REQ-010

In addition to the submissions for the different Reviews, the Supplier shall agree with F4E the frequency of submittal of the different Supplier RMV deliverables (RPMs and VCDs) in order to feed the correspondent inputs to the F4E RMVDB.

#>

4 QA-119 REQUIREMENTS APPLICABILITY

As an explanation, the following table indicates the standard applicability of the requirements depending on whether it is a Design & Manufacturing contract, Design only or Manufacturing only and depending on the maturity in the case of contracts including design activities. The applicability for each contract is to be established in [RD-007].

APPLICABILITY EXAMPLES		Design Contract			Construction Contract	Design & Construction Contract		
Requirement	Topic	FS	DD	BTP	BTP	FS	DD	BTP
RMV4S-REQ-001	Supplier RMVDB	YES	YES	YES	YES	YES	YES	YES
RMV4S-REQ-002	Supplier RMVDB contents	YES	YES	YES	YES	YES	YES	YES
RMV4S-REQ-003	Supplier RMVDB use	YES	YES	YES	YES	YES	YES	YES
RMV4S-REQ-004	SRMVDB/F4E RMVDB Interface	YES	YES	YES	YES	YES	YES	YES
RMV4S-REQ-005	PDR deliverables	YES	NA	NA	NA	YES	NA	NA
RMV4S-REQ-006	FDR deliverables	YES	YES	NA	NA	YES	YES	NA
RMV4S-REQ-007	MRR deliverables (design & manufacturing contracts)	NA	NA	NA	NA	YES	YES	NA
RMV4S-REQ-008	MRR deliverables (manufacturing only contracts)	NA	NA	NA	YES	NA	NA	YES
RMV4S-REQ-009	Final ADP deliverables	NA	NA	NA	YES	YES	YES	YES
RMV4S-REQ-010	Frequency of intermediate deliveries	YES	YES	YES	YES	YES	YES	YES

Table 3: QA-119 Applicability Matrix

- End of the Document -